

3-POINT LOG SPLITTER

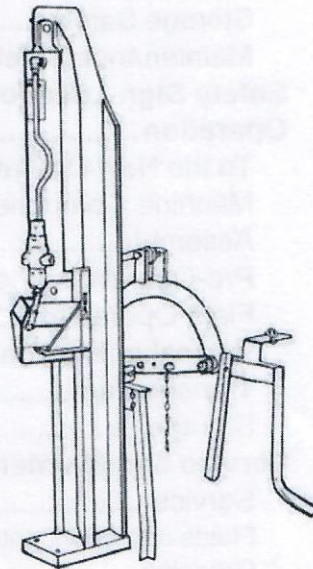

**Assembly, Parts
& Operator's Manual**

TABLE OF CONTENTS

SECTION	DESCRIPTION	PAGE
1	Introduction	1
1.1	Serial Number Location	2
2	Safety	3
2.1	General Safety	4
2.2	Equipment Safety Guidelines	5
2.3	Safety Training	6
2.4	Safety Signs	6
2.5	Preparation	7
2.6	Hydraulic Safety	7
2.7	Operating Safety	8
2.8	Transport Safety	9
2.9	Storage Safety	9
2.10	Maintenance Safety	9
3	Safety Sign Locations	10
4	Operation	11
4.1	To the New Operator or Owner	11
4.2	Machine Components	11
4.3	Assembly	12
4.4	Pre-Operation Checklist	13
4.5	Field Operation	14-16
4.6	Vertical to Horizontal Conversion	17
4.7	Transporting	18
4.8	Storage	18
5	Service and Maintenance	19
5.1	Service	19
5.1.1	Fluids and Lubricants	19
5.1.2	Greasing	19
5.1.3	Servicing Intervals	19
5.2	Maintenance	20
5.2.1	Changing Seals in Valve	20
5.3	Premature Kick-Out	21
6	Trouble Shooting	22
7	Specifications	23
7.1	Mechanical	23
7.2	Bolt Torque	24
8	Parts Breakdown	25
8.1	Log Splitter	25-26
8.2	Hydraulic Valve Assembly	27
8.3	Conversion-Open to Closed Center Valve	28
9	Limited Warranty	29

1 INTRODUCTION

Congratulations on your choice of a 3 Point Hitch Log Splitter to complement your log splitting operation. This equipment has been designed and manufactured to meet the needs of a discriminating buyer for the efficient splitting of logs.

The Gearmore 3-point, PTO driven Log Splitter is the latest compact designed splitter. The Log Splitter can be used in the vertical or horizontal position.

Safe, efficient and trouble free operation of your Log Splitter requires that you and anyone else who will be operating or maintaining the machine, read and understand the Safety, Operation, Maintenance and Trouble Shooting information contained within the Operator's Manual.

This manual covers the 3 Point Hitch Log Splitter. Use the Table of Contents as a guide to locate required information.

Keep this manual handy for frequent reference and to pass on to new operators or owners. Call your dealer if you need assistance, information or additional copies of the manuals.

OPERATOR ORIENTATION - The directions left, right, front and rear, as mentioned throughout this manual, are as seen from the driver's seat and facing in the direction of travel.

1.1 SERIAL NUMBER LOCATION

Always give your dealer the serial number of your 3 Point Hitch Log Splitter when ordering parts or requesting service or other information.

The serial number plate is located where indicated. Please mark the number in the space provided for easy reference.

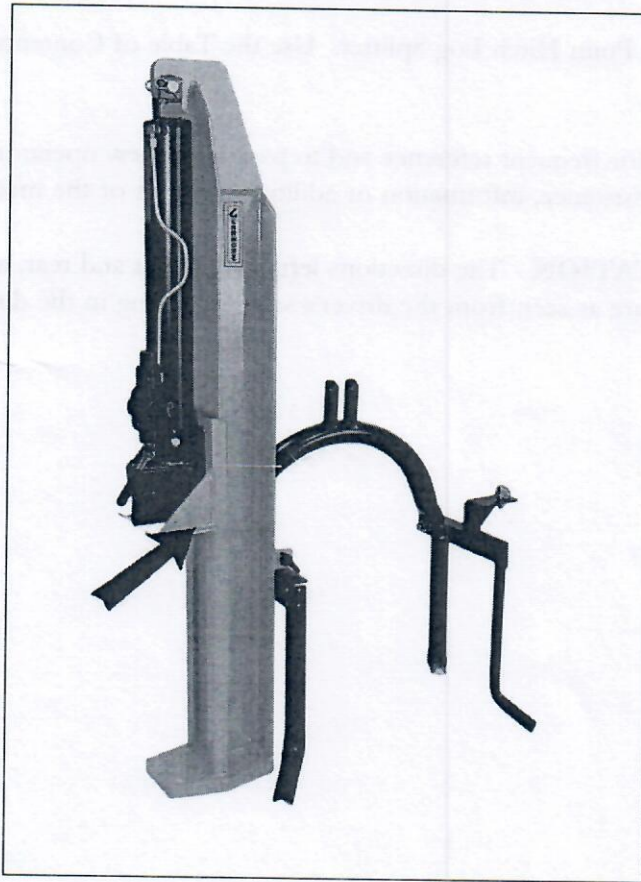

Model No: _____

Serial No: _____

Date of Purchase: _____

2 SAFETY

SAFETY ALERT SYMBOL

This Safety Alert symbol means **ATTENTION! BECOME ALERT! YOUR SAFETY IS INVOLVED!**



The Safety Alert symbol identifies important safety messages on the Gearmore Log Splitter and in the manual. When you see this symbol, be alert to the possibility of personal injury or death. Follow the instructions in the safety message.

Why is SAFETY important to you?

3 Big Reasons

Accidents Disable and Kill
Accidents Cost
Accidents Can Be Avoided

SIGNAL WORDS:

Note the use of the signal words **DANGER**, **WARNING** and **CAUTION** with the safety messages. The appropriate signal word for each message has been selected using the following guide-lines:

SI NO LEE INGLES, PIDA AYUDA A AIGUIEN QUE SI LO LEA PARA QUE LE TRADUZCA LAS MIDIDAS DE SEGURIDAD.

DANGER - Indicates an imminently hazardous situation that, if not avoided, will result in death or serious injury. This signal word is to be limited to the most extreme situations typically for machine components which, for functional purposes, cannot be guarded.

WARNING - Indicates a potentially hazardous situation that, if not avoided, could result in death or serious injury, and includes hazards that are exposed when guards are removed. It may also be used to alert against unsafe practices.

CAUTION - Indicates a potentially hazardous situation that, if not avoided, may result in minor or moderate injury. It may also be used to alert against unsafe practices.

If you have any questions not answered in this manual or require additional copies or the manual is damaged, please contact your dealer.

SAFETY

YOU are responsible for the **SAFE** operation and maintenance of your 3 Point Hitch Log Splitter. **YOU** must ensure that you and anyone else who is going to operate, maintain or work around the Log Splitter be familiar with the operating and maintenance procedures and related **SAFETY** information contained in this manual. This manual will take you step-by-step through your working day and alerts you to all good safety practices that should be adhered to while operating the Log Splitter.

Remember, **YOU** are the key to safety. Good safety practices not only protect you but also the people around you. Make these practices a working part of your safety program. Be certain that **EVERYONE** operating this equipment is familiar with the recommended operating and maintenance procedures and follows all the safety precautions. Most accidents can be prevented. Do not risk injury or death by ignoring good safety practices.

- Log Splitter owners must give operating instructions to operators or employees before allowing them to operate the machine, and at least annually thereafter per OSHA (Occupational Safety and Health Administration) regulation 1928.57.
- The most important safety feature on this equipment is a **SAFE** operator. It is the operator's responsibility to read and understand **ALL** Safety and Operating instructions in the manual and to follow these. Most accidents can be avoided.
- A person who has not read and understood all operating and safety instructions is not qualified to operate the machine. An untrained operator exposes himself and bystanders to possible serious injury or death.
- Do not modify the equipment in any way. Unauthorized modification may impair the function and/or safety and could affect the life of the equipment.
- **Think SAFETY! Work SAFELY!**

2.1 GENERAL SAFETY

1. Read and understand the Operator's Manual and all safety signs before operating, maintaining, adjusting or unplugging the Log Splitter.



2. Have a first-aid kit available for use should the need arise and know how to use it.



3. Have a fire extinguisher available for use should the need arise and know how to use it.



4. Wear appropriate protective gear. This list includes but is not limited to:

- A hard hat
- Protective shoes with slip resistant soles
- Protective goggles, glasses or face shield
- Heavy gloves
- Protective clothing



5. Install and secure all guards before starting.
6. Do not allow riders.
7. Wear suitable ear protection for prolonged exposure to excessive noise.
8. Place all controls in neutral, stop tractor engine, set park brake, remove ignition key and wait for all moving parts to stop before servicing, adjusting, repairing or unplugging.
9. Clear the area of people, especially small children, before starting.
10. Review safety related items annually with all personnel who will operating or maintaining the Log Splitter.



2.2 EQUIPMENT SAFETY GUIDELINES

1. Safety of the operator and bystanders is one of the main concerns in designing and developing a machine. However, every year many accidents occur which could have been avoided by a few seconds of thought and a more careful approach to handling equipment. You, the operator, can avoid many accidents by observing the following precautions in this section. To avoid personal injury or death, study the following precautions and insist those working with you, or for you, follow them.
2. In order to provide a better view, certain photographs or illustrations in this manual may show an assembly with a safety shield removed. However, equipment should never be operated in this condition. Keep all shields in place. If shield removal becomes necessary for repairs, replace the shield prior to use.
3. Replace any safety sign or instruction sign that is not readable or is missing. Location of such safety signs is indicated in this manual.
4. Never use alcoholic beverages or drugs which can hinder alertness or coordination while operating this equipment. Consult your doctor about operating this machine while taking prescription medications.
5. **Under no circumstances should young children be allowed to work with this equipment. Do not allow persons to operate or assemble this unit until they have read this manual and have developed a thorough understanding of the safety precautions and of how it works.** Review the safety instructions with all users annually.
6. This equipment is dangerous to children and persons unfamiliar with its operation. The operator should be a responsible, properly trained and physically able person familiar with farm machinery and trained in this equipment's operations. If the elderly are assisting with work, their physical limitations need to be recognized and accommodated.
7. Use a tractor equipped with a Roll Over Protective Structure (ROPS) and a seat belt.
8. Never exceed the limits of a piece of machinery. If its ability to do a job, or to do so safely, is in question - **DON'T TRY IT.**
9. **Do not** modify the equipment in any way. Unauthorized modification may result in serious injury or death and may impair the function and life of the equipment.
10. In addition to the design and configuration of this implement, including Safety Signs and Safety Equipment, hazard control and accident prevention are dependent upon the awareness, concern, prudence, and proper training of personnel involved in the operation, transport, maintenance, and storage of the machine. Refer also to Safety Messages and operation instruction in each of the appropriate sections of the Tractor and machine Manuals. Pay close attention to the Safety Signs affixed to the Tractor and the machine.

2.3 SAFETY TRAINING

1. Safety is a primary concern in the design and manufacture of our products. Unfortunately, our efforts to provide safe equipment can be wiped out by a single careless act of an operator or bystander.
2. In addition to the design and configuration of equipment, hazard control and accident prevention are dependent upon the awareness, concern, prudence and proper training of personnel involved in the operation, transport, maintenance and storage of this equipment.
3. It has been said, "The best safety feature is an informed, careful operator." We ask you to be that kind of an operator. It is the operator's responsibility to read and understand ALL Safety and Operating instructions in the manual and to follow these. Accidents can be avoided.
4. **Working with unfamiliar equipment can lead to careless injuries. Read this manual, and the manual for your tractor, before assembly or operating, to acquaint yourself with the machines. If this machine is used by any person other than yourself, or is loaned or rented, it is the machine owner's responsibility to make certain that the operator, prior to operating:**
 - a. Reads and understands the operator's manuals.
 - b. Is instructed in safe and proper use.
5. Know your controls and how to stop tractor engine, and machine quickly in an emergency. Read this manual and the one provided with your tractor.
6. Train all new personnel and review instructions frequently with existing workers. Be certain only a properly trained and physically able person will operate the machinery. A person who has not read and understood all operating and safety instructions is not qualified to operate the machine. An untrained operator exposes himself and bystanders to possible serious injury or death. If the elderly are assisting with farm work, their physical limitations need to be recognized and accommodated.

2.4 SAFETY SIGNS

1. Keep safety signs clean and legible at all times.
2. Replace safety signs that are missing or have become illegible.
3. Replaced parts that displayed a safety sign should also display the current sign.
4. Safety signs are available from your authorized Distributor or Dealer Parts Department or the factory.

How to Install Safety Signs:

- Be sure that the installation area is clean and dry.
- Be sure temperature is above 50°F (10°C).
- Determine exact position before you remove the backing paper. (See Section 3).
- Remove the smallest portion of the split backing paper.
- Align the sign over the specified area and carefully press the small portion with the exposed sticky backing in place.
- Slowly peel back the remaining paper and carefully smooth the remaining portion of the sign in place.
- Small air pockets can be pierced with a pin and smoothed out using the piece of sign backing paper.

2.5 PREPARATION

1. Never operate the tractor and machine until you have read and completely understand this manual, the Tractor Operator's Manual, and each of the Safety Messages found on the safety signs on the tractor and machine.

2. Personal protection equipment including hard hat, safety glasses, safety shoes, and gloves are recommended during assembly,

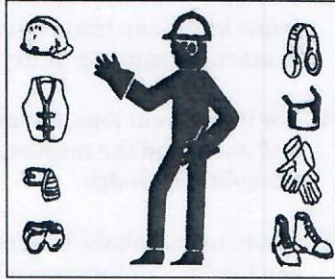

installation, operation, adjustment, maintaining, repairing, removal, or moving the implement. Do not allow long hair, loose fitting clothing or jewelry to be around equipment.

3. **PROLONGED EXPOSURE TO LOUD NOISE MAY CAUSE PERMANENT HEARING LOSS!**

Tractors with or without equipment attached can often be noisy enough to cause permanent, partial hearing loss. We recommend that you wear hearing protection on a full-time basis if the noise in the Operator's position exceeds 80db. Noise over 85db on a long-term basis can cause severe hearing loss. Noise over 90db adjacent to the Operator over a long-term basis may cause permanent, total hearing loss. **NOTE:** Hearing loss from loud noise (from tractors, chain saws, radios, and other such sources close to the ear) is cumulative over a lifetime without hope of natural recovery.

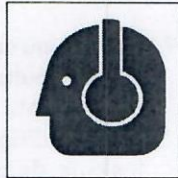

4. Operate the machine only with a tractor equipped with an approved Roll-Over-Protective Structure (ROPS). Always wear your seat belt. Serious injury or even death could result from falling off the tractor ---particularly during a turnover when the operator could be pinned under the ROPS or the tractor.



5. Clear working area of stones, branches or hidden obstacles that might be hooked or snagged, causing injury or damage.
6. Operate only in daylight or good artificial light.
7. Be sure machine is properly mounted, adjusted and in good operating condition.
8. Ensure that all safety shielding and safety signs are properly installed and in good condition.

2.6 HYDRAULIC SAFETY

1. Make sure that all the components in the hydraulic system are kept in good condition and are clean.
2. Replace any worn, cut, abraded, flattened or crimped hoses and metal lines.
3. Stop engine or motor, disconnect spark plug wire or unplug power cord, and wait for all moving parts to stop before servicing, adjusting, repairing or cleaning.
4. Do not attempt any makeshift repairs to the hydraulic lines, fittings or hoses by using tapes, clamps or cements. The hydraulic system operates under extremely high-pressure. Such repairs will fail suddenly and create a hazardous and unsafe condition.

5. Wear proper hand and eye protection when searching for a high-pressure hydraulic leak. Use a piece of wood or cardboard as a backstop instead of hands to isolate and identify a leak.

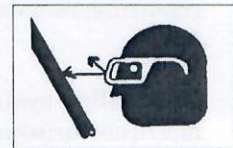

6. If injured by a concentrated high-pressure stream of hydraulic fluid, seek medical attention immediately. Serious infection or toxic reaction can develop from hydraulic fluid piercing the skin surface.
7. Before applying pressure to the system, make sure all components are tight and that lines, hoses and couplings are not damaged.

- **Think SAFETY! Work SAFELY!**

2.7 OPERATING SAFETY

1. Please remember it is important that you read and heed the safety signs on the Log Splitter. Clean or replace all safety signs if they cannot be clearly read and understood. They are there for your safety, as well as the safety of others. The safe use of this machine is strictly up to you, the operator.
2. All things with moving parts are potentially hazardous. There is no substitute for a cautious, safe-minded operator who recognizes potential hazards and follows reasonable safety practices. The manufacturer has designed this Log Splitter to be used with all its safety equipment properly attached, to minimize the chance of accidents. Study this manual to make sure you have all safety equipment attached.
3. If a safety shield or guard is removed for any reason, it must be replaced before the machine is again operated.
4. Personal protection equipment including hard hat, safety glasses, hearing protection, safety shoes, and tight gloves are recommended during assembly, installation, operation, adjustment, maintaining, repairing, removal, or moving. Do not allow long hair, loose fitting clothing, or jewelry to be around moving parts.
5. Always use two people to handle heavy, unwieldy components during assembly, installation, removal or moving.
6. Never place any part of your body, fingers, hands, feet, etc. where it would be in danger if movement should occur during assembly, installation, operation, maintaining, repairing, removal or moving. Keep others away.
7. Do not allow bystanders within 20 feet of machine during operation. Wood chips can fly out and injure others.
8. Do not step over or straddle splitter during operation.
9. Do not try to split more than one log at a time. The extra log can fly out and cause injury.
10. Keep your fingers and hands away from cracks in the log that can open while splitting.
11. Always load logs by holding on the sides, not the top and bottom.
12. Do not load the splitter when the wedge is in motion.
13. Do not try to split logs across the grain. Some kinds can burst or splinter and fly out of machine causing injury.
14. For uneven cut logs, always place the wide end down and the most square kind against the splitting wedge.
15. Never use alcoholic beverages or drugs which can hinder alertness or coordination while operating this equipment. Consult your doctor about operating this machine while taking prescription medications.
16. Do not allow riders on the machine or tractor at any time. There is no safe place for any riders.
17. Before you operate the machine, check over all pins, bolts, connections and hydraulic components to be sure all are securely in place and tight. Tighten or replace any leaking, damaged or worn parts immediately.
18. Do not allow anyone who is not familiar with the safety rules and operation instructions to use this machine.
19. Never allow children to operate or be around this machine.
20. Use stabilizer bars, adjustable sway chains, or sway blocks on the tractor lift arms to keep the machine from swinging side to side. Adjust as tightly as practical for best performance.
21. Do not operate on slopes or hillsides. Sloping terrain can cause logs to roll or slip.
22. Clear the work area of objects which might be picked up and snagged or entangled in the machine. Do not operate on slippery, wet, muddy or icy surfaces. Good footing prevents slipping and tripping.

2.8 TRANSPORT SAFETY

1. Comply with state and local laws governing highway safety and movement of machinery on public roads.
2. The use of flashing amber lights is acceptable in most localities. However, some localities prohibit their use. Local laws should be checked for all highway lighting and marking requirements.
3. At all times, when driving the tractor and equipment on the road or highway under 20 mph (32 kph) use flashing amber warning lights and a slow moving vehicle (SMV) identification emblem. Do not exceed 20 mph (32 kph). Reduce speed on rough roads and surfaces.
4. Plan your route to avoid heavy traffic.
5. Always install transport locks, pins or brackets before transporting.
6. Do not drink and drive.
7. Be a safe and courteous driver. Always yield to oncoming traffic in all situations, including narrow bridges, intersections, etc. Watch for traffic when operating near or crossing roadways.
8. Turn into curves or go up or down hills only at a low speed and at a gradual steering angle. Make certain that at least 20% of the tractor's weight is on the front wheels to maintain safe steering. Slow down on rough or uneven surfaces.
9. A heavy load can cause instability of the tractor. Use extreme care during travel. Slow down on turns and watch out for bumps. The tractor may need front counterweights to counterbalance the weight of the machine.
10. Never allow riders on either tractor or machine.

2.9 STORAGE SAFETY

1. Store the unit in an area away from human activity.
2. Do not permit children to play on or around the stored machine.
3. Store the unit in a dry, level area. Support the frame with planks if required.

2.10 MAINTENANCE SAFETY

1. Good maintenance is your responsibility. Poor maintenance is an invitation to trouble.
2. Follow good shop practices.
 - Keep service area clean and dry.
 - Be sure electrical outlets and tools are properly grounded.
 - Use adequate light for the job at hand.
3. Make sure there is plenty of ventilation. Never operate the engine of the towing vehicle in a closed building. The exhaust fumes may cause asphyxiation.
4. Before working on this machine, shut off the engine, set the brakes, and remove the ignition keys.
6. Never work under equipment unless it is blocked securely.
7. Use personal protection devices such as eye, hand and hearing protectors, when performing any service or maintenance work.
8. Where replacement parts are necessary for periodic maintenance and servicing, genuine factory replacement parts must be used to restore your equipment to original specifications. The manufacturer will not be responsible for injuries or damages caused by use of unapproved parts and/or accessories.
9. A fire extinguisher and first aid kit should be kept readily accessible while performing maintenance on this equipment.
10. Periodically tighten all bolts, nuts and screws and check that all cotter pins are properly installed to ensure unit is in a safe condition.
11. When completing a maintenance or service function, make sure all safety shields and devices are installed before placing unit in service.



3 SAFETY SIGN LOCATIONS

The types of safety signs and locations on the equipment are shown in the illustration below. Good safety requires that you familiarize yourself with the various safety signs, the type of warning and the area, or particular function related to that area, that requires your SAFETY AWARENESS.



**ALWAYS REPLACE
MISSING OR
DAMAGED DECALS**

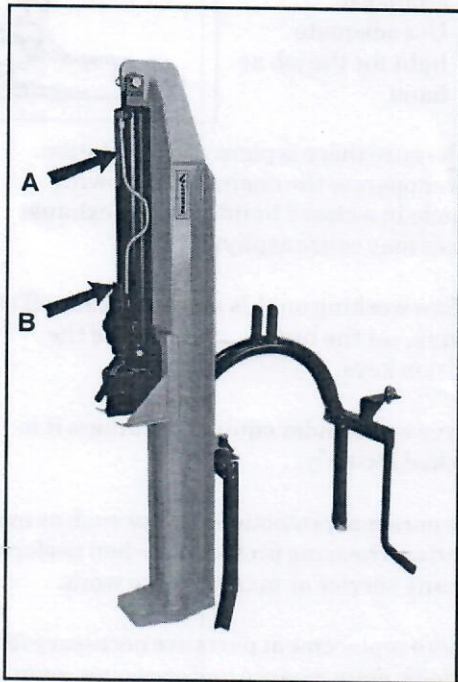

Part No. DL51-1-57

Location: Top, forward section of hydraulic cylinder

A



WARNING

1. Read and understand Operator's Manual thoroughly before operation. Failure to do so may result in serious injury.
2. Keep all shields in place.
3. Keep hands, feet and clothing away from power driven parts.
4. Always wear safety glasses and safety shoes during operation.
5. Always operate out-of-doors with good ventilation.
6. Always stop engine and remove spark plug wire before performing maintenance operations.
7. Always shut off engine when leaving log splitter unattended, even for a short period of time.
8. Only one person should load and operate the log splitter. Keep all others clear during operation. Never allow one person to operate valve while another is positioning the log.
9. Always position log with hands on the sides of log. Keep hands clear of ends.
10. Keep all children away from the log splitter.
11. Do not step over the log splitter.
12. Only use hands to operate the control valve.
13. Do not operate the log splitter while under the influence of alcohol, drugs or medication.
14. Always operate the log splitter on level, dry, non-slippery surfaces. Keep off slopes.
15. Keep work area clear of split wood, debris or other obstacles.
16. Always stay in the operator zone when using the log splitter.
17. Always split wood in the direction of the grain only.
18. Do not add gasoline while the engine is hot or running. Allow all spilled gas to evaporate before using log splitter.

Part No. DL51-1-32

Location: Top of hydraulic cylinder

REMEMBER - If safety signs have been damaged, removed, become illegible or parts replaced without signs, new signs must be applied. New signs are available from your authorized dealer.

4 OPERATION



OPERATING SAFETY

1. Read and understand the Operator's Manual and all safety signs before operating, servicing, adjusting, repairing or unplugging.
2. Do not allow riders.
3. Install and secure all guards and shields before starting or operating.
4. Keep hands, feet, hair and clothing away from moving parts.
5. Place all controls in neutral, stop tractor engine, set park brake, remove ignition key and wait for all moving parts to stop before servicing, adjusting, repairing or unplugging.
6. Place all tractor and machine controls in neutral before starting.
7. Always wear the appropriate personal safety equipment when operating splitter including but not limited to hard hat, safety shoes, face shield and heavy gloves.
8. Clear the area of bystanders, especially small children, before starting.
9. Do not operate on slopes or sidehills.
10. Keep working area clean, neat and dry to prevent slipping and tripping.
11. Keep all mechanical and hydraulic components in good condition. Do not operate with leaks or damaged components.
12. Load splitter by holding logs on the side rather than the top and bottom.
13. Do not split wood across the grain.
14. Review safety instructions with all operators annually.

4.1 TO THE NEW OPERATOR OR OWNER

The 3 Point Hitch Log Splitter is designed to split any kind of wood or log. Be familiar with the machine before starting.

It is the responsibility of the owner or operator to read this manual and to train all other operators before they start working with the machine. Follow all safety instructions exactly. Safety is everyone's business. By following recommended procedures, a safe working environment is provided for the operator, bystanders and the area around the worksite. Untrained operators are not qualified to operate the machine.

Many features incorporated into this machine are the result of suggestions made by customers like you. Read this manual carefully to learn how to operate the machine safely and how to set it to provide maximum field efficiency. By following the operating instructions in conjunction with a good maintenance program, your Log Splitter will provide many years of trouble-free service.

4.2 MACHINE COMPONENTS

The 3 Point Hitch Log Splitter consists of a wedge on the end of a hydraulic cylinder for splitting wood or logs. Hydraulic power from the tractor is routed through a double acting valve to control the cylinder position. The wedge is designed with a stripper to remove stuck logs as the wedge is retracted. The Splitter can be used in vertical or horizontal configuration.

4.3 ASSEMBLY

The machine is shipped from the factory in a partially disassembled form that allows for easy and convenient shipping. Refer to the drawing and parts list should it become necessary to disassemble the unit for repair or replacement of parts.

When preparing for the customer, follow this procedure:

Step 1: After you have cleared the area of bystanders, especially small children, remove all components from the crate. Inspect each piece for shipping damage. If any part is damaged, contact your dealer or delivering carrier. Use two men to guide or direct and handle the heavy and bulky components. Use a crane, hoist or forklift of sufficient capacity and stability to handle the components.

Step 2: Attach the four legs to the A-frame stand using the $\frac{5}{16}$ " NC x 1 $\frac{1}{2}$ " hex cap screws, $\frac{5}{16}$ " lockwashers, and $\frac{5}{16}$ " hex nuts. Tighten.

Step 3: Insert the draw pins into the lower holes on the A-frame stand. Secure with $\frac{7}{8}$ " lockwashers and $\frac{7}{8}$ " hex nuts. Tighten.

Step 4: Stand the beam on end. Check to see that it is stable. Line up the bracket holes on the A-frame stand with the two ears on the beam and insert the pivot pin. Secure with clip pin.

Step 5: Insert the stub pin through the hole on the A-frame stand from underneath. Secure with $\frac{7}{8}$ " lockwasher and $\frac{7}{8}$ " hex nut.

Step 6: Carefully lower the beam to the horizontal position. Be certain that the ground stand is securely in place. Put the lynch pin through the hole in the stub pin to hold the beam in place.

Step 7: Attach the hydraulic fittings provided in the hardware kit to the valve.

Step 8: Back the tractor into position and slide the lift arms over the draw pins on the A-frame/stand and secure with a top link pin and a lynch pin (not provided).

Step 9: IMPORTANT - The tractor must be able to handle Cat. I or II 3-point hitch implements and be equipped with a four-way valve (for double acting cylinders) and hydraulic outlets.

The tractor owner's manual should be consulted for instructions on tractor operation, safety, and auxiliary hydraulic systems pumping and return flow hookups.

Determine the easiest position to lock the tractor's valve lever in the operating position. Then locate the pressure and return ports with the valve locked in this position. Connect the hoses from the tractor to the Log Splitter with the flow from the pressure port entering on the "IN" side of the valve. The return flow to the tractor should come from the "OUT" side. (*Note: Ports are $\frac{1}{2}$ " NPT*)

After connecting the hoses to the valve, the system should be energized by moving the tractor auxiliary valve in the direction to cause oil flow. Tie in place. Oil should flow in only one direction through the hydraulic valve. If the tractor auxiliary valve is moved to the wrong position, the Log Splitter relief valve will not operate and damage to the tractor system or Log Splitter could result.

The tractor hydraulic system should be capable of delivering 6 to 25 GPM of oil at 1500 to 2500 PSI for adequate splitting force and speed. The tractor should have a cooling system to allow semi-continuous operation.

NOTE: Specifications of the hoses and fittings supplied by the owner should be within recommended ranges of the tractor operating pressure.

Step 10: Using the tractor 3-point hitch, raise the Log Splitter to a convenient height and level with the top link. The Log Splitter may be operated in either the horizontal or vertical position.

4.4 PRE-OPERATION CHECKLIST

Although there are no operational restrictions on the Log Splitter when used for the first time, it is recommended that the following mechanical items be checked:

A. After Operating For 1 and 5 Hours:

1. Check all nuts, bolts and other fasteners. Tighten to their specified torque level.
2. Check hydraulic system for leaks. Tighten all leaking fittings and replace any leaking components.
3. Then go to the service schedule as defined in the Maintenance Section.

Efficient and safe operation of the Log Splitter requires that each operator reads and understands the operating procedures and all related safety precautions outlined in this section. A pre-operation checklist is provided for the operator. It is important for both the personal safety and maintaining the good mechanical condition of the Log Splitter that this checklist is followed.

Before operating the machine and each time thereafter, the following areas should be checked off:

1. Use only a small Agricultural tractor of less than 100 horsepower on the machine.
2. Check that the machine is properly attached to the tractor. Be sure retainers are used on the mounting pins.
3. Be sure extra weights are mounted on the front of the tractor if required.
4. Check the wedge and strippers. Be sure they are not damaged or broken and is not badly worn. Repair or replace as required.
5. Check for entangled material. Remove this material.
6. Check for hydraulic leaks, tighten fittings or replace components to stop leaks.

4.5 FIELD OPERATION



OPERATING SAFETY

1. Read and understand the Operator's Manual and all safety signs before operating, servicing, adjusting, repairing or unplugging.
2. Do not allow riders.
3. Install and secure all guards and shields before starting or operating.
4. Keep hands, feet, hair and clothing away from moving parts.
5. Place all controls in neutral, stop tractor engine, set park brake, remove ignition key and wait for all moving parts to stop before servicing, adjusting, repairing or unplugging.
6. Place all tractor and machine controls in neutral before starting.
7. Always wear the appropriate personal safety equipment when operating splitter including but not limited to hard hat, safety shoes, face shield and heavy gloves.
8. Clear the area of bystanders, especially small children, before starting.
9. Do not operate on slopes or sidehills.
10. Keep working area clean, neat and dry to prevent slipping and tripping.
11. Keep all mechanical and hydraulic components in good condition. Do not operate with leaks or damaged components.
12. Load splitter by holding logs on the side rather than the top and bottom.
13. Do not split wood across the grain.
14. Review safety instructions with all operators annually.

Log Splitters attach to a tractor 3 point hitch and use the tractor hydraulics to move a wedge through wood to split it. The splitter can be used in the vertical or horizontal configuration. However the operator has the responsibility of being familiar with all operating and safety procedures and following them.

Each operator should review this section of the manual at the start of the season and as often as required to be familiar with the machine. When using, follow this procedure:

1. Review and follow the Pre-Operation Checklist.
2. Attach the tractor to the machine.
 - a. Position the arms and slide the balls over the mounting pins. Install the retainers.
 - b. Attach the top link to the mast. Install the retainer.

IMPORTANT

Do not use on a tractor of more than 100 horsepower.

- c. Always engage the anti-sway components on each lift arm to keep the unit from moving from side-to-side during operation.
 - d. The frame is designed to attach to a Category I or II, 3 point hitch. Be sure to use the appropriate sized mounting pins and bushings when attaching to tractor.
3. **Attach the Hydraulics:**
 - a. Use a clean cloth or paper towel to clean the tips on the end of the hoses and the area around the couplers on the tractor.

IMPORTANT

Use the remote circuit of the tractor that is designed with a detent. The circuit can then be turned on and stay on while the splitter is being used.

- b. Insert the male ends into the couplers on the tractor. Be sure they are locked in place.

NOTE

The tractor can be equipped with either a closed-center or open-centered hydraulic system.

- c. Route the hoses over the hitch and secure in position with clips, tape or plastic ties. Provide sufficient slack for raising and lowering the 3 point hitch.



4. Before going to the working area review Section 4.7 Transporting.
5. Drive to the working area and stop in a level area.
6. Lower into working position, stop engine and set park brake.
7. **Set the Machine:**
 - a. **Level the Frame:**

Use the screw jack on the right lift arm to level the frame from side-to-side.

- b. **Frame Angle:**

Use the turnbuckle on the top link to set the frame angle. Normally the frame should be set parallel to the ground or vertical depending on the configuration.

8. **Controls:**

The splitter is designed with a 3 position hydraulic valve that controls the flow of oil through the system.

- a. **Cylinder Ram Extending for Splitting:**

Move the lever toward the base and hold it to have the cylinder ram extend to move the wedge for splitting. This position is spring-loaded and must be held for the wedge to move and split.

- b. **Center Neutral Position:**

In the centered neutral position the hydraulic oil from the tractor is bypassed and returned to the tractor. The wedge will not move.

- c. **Cylinder Ram Retracting for Resetting:**

Move the lever toward the cylinder end and it will go into detent. While in detent, the wedge will continue to retract until it reaches the end of its stroke, goes over relief and pops out of detent. This feature allows the operator to remove the split portions of the log and get a new log while the wedge retracts.

NOTE

Be sure the splitter relief pressure is set below the tractor relief pressure or the tractor hydraulics will pop out of its detent rather than the splitter.

- d. Be sure to select the hydraulic circuit on the tractor with a detent to provide a constant flow of oil to the machine.

9. **Starting:**

- a. Move tractor into its working position, lower the frame to the ground and set park brake. Be sure the working area is level, dry and free of obstructions.

IMPORTANT

If the parking brakes don't hold the tractor, chock the wheels front and rear.

- b. Place the throttle in its mid-range position.
- c. Place the working hydraulic circuit in detent.
- d. Move the splitting wedge/cylinder to its fully retracted position.
- e. Position log between the wedge and the base of the frame.
- f. Move the hydraulic lever toward the base and hold it while the wedge moves through the log.
- g. Release the lever when the log splits into 2 pieces or the wedge reaches the base and the wedge will stop.
- h. Move the lever in the fully up retracting direction into detent and it will retract fully. When fully retracted, the pressure will exceed 1200 PSI, the control lever will pop out of detent and the wedge will stop moving.

10. Log Placement:

- a. Always grasp the log by the sides when placing in the splitter. This will minimize the chance of the operator getting their fingers or arm between the wedge and the log.
- b. Always wear the appropriate safety gear when working around the machine. This includes but is not limited to:
 - Hard hat for protection to the head.
 - Face mask for protection to the face and eyes from flying chips.
 - Heavy gloves for protection from slivers, chips and pinching.
 - Safety shoes with slip resistant soles for protection to the feet and toes from dropped logs and pieces of wood. Slip resistant soles reduce the chance of slipping.

11. Log Stripper:

Each machine is designed with a log stripper located next to the wedge when it is in its retracted position. The stripper consists of a stationary bracket on each side of the frame that will push a log or block of wood off the wedge as it retracts. Always remove all wood from wedge before proceeding with the next split.

12. Operating Hints:

- a. Hold the hydraulic lever in the wedge extend direction until the wedge reaches the base or the log/wood splits. Move it into detent in the opposite direction to retract the wedge. The lever will kick out of detent when it is fully retracted.
- b. In cool or cold operating conditions, the oil can be so viscous that the detent will not work in the retract wedge mode. The system will kick out of detent when the back pressure exceeds more than 200 psi. Warm the oil by holding the control lever over relief for a few minutes. As the oil circulates, it will warm the system and the detent will function normally.
- c. Always keep the working area neat and clean to prevent tripping. Pile the split and unsplit wood in piles close to the working area. Do not allow pieces to pile up and clutter the area. A cluttered working area can lead to tripping and an accident. Do not take chances with safety.
- d. Do not place the splitter on muddy, icy, wet or cluttered surfaces. Each can lead to slipping or tripping and cause accidents.
- e. Lubricate the plate under the wedge slider each time the machine is used to improve wear and reduce friction and/or binding.

IMPORTANT - To extend the life of the hydraulic cylinder, avoid "bottoming out" wedge plate to the foot piece. To conform with industry safety recommendations, the wedge stops 2 inches from the end of the stroke.

4.6 VERTICAL TO HORIZONTAL CONVERSION

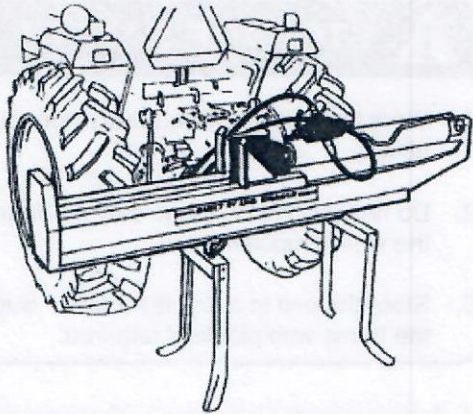

Log Splitter quickly converts to the horizontal position. Just lower the beam on hinge and lock in place with lynch pin.

The Splitter works well in either the vertical or horizontal configuration. To convert from vertical to horizontal configuration, follow this procedure:

1. Clear the area of bystanders, especially small children.
2. Be sure to have a couple of men to handle the heavy components or use a hoist, lift or forklift with the appropriate capacity to handle the weight.
3. Set the base on the ground, relieve the pressure in the hydraulic circuit by moving the control lever through neutral several times, set the park brake and stop the engine.
4. Disconnect the hydraulic lines from the couplers on the tractor and lay to the side so they will not be pinched.
5. Disconnect the top link.
6. Disconnect the lift arms from the mounting pins.
7. Use 2 men and/or an appropriate lift assist to lay the machine on the ground with the cylinder down.
8. Remove the bolts from the hitch frame mounting plate.
9. Turn the hitch frame 180° and re-attach to the mast. Tighten fasteners to their specified torque.
10. Remove the 2, 3 point hitch mounting pins and move to their new position at the lower part of the legs. Tighten fasteners to their specified torque.
11. Turn the Log Splitter over so the cylinder is on top.
12. **Attach to the Tractor:**
 - a. Slide the lift arms over the mounting pins and install the retainers.
 - b. Connect the top link and install the retainer.
 - c. Level the frame using the lift arm and the turnbuckle in the top link.
 - d. Connect the hydraulics.
 - Use a clean cloth or paper towel to clean the tips on the end of the hoses and the area around the couplers on the tractor.
 - Insert the male ends into the couplers on the tractor. Be sure they are locked in place.
 - Route the hoses over the hitch and secure in position with clips, tape or plastic ties. Provide sufficient slack for raising.



WARNING: Tilt slowly!
DO NOT move from vertical to horizontal position unless frame legs are securely in place. Tractor lift arms could fall resulting in serious injury.

4.7 TRANSPORTING



TRANSPORT SAFETY

1. Make sure you are in compliance with all local regulations regarding transporting equipment on public roads and highways.
2. Make sure the SMV (Slow Moving Vehicle) emblem and all the lights and reflectors that are required by the local highway and transport authorities are in place, are clean and can be seen clearly by all overtaking and oncoming traffic.
3. Do not allow anyone to ride on the Log Splitter or tractor during transport.
4. Do not exceed 20 mph (32 kph). Reduce speed on rough roads and surfaces.
5. Use retainers on the mounting pins when attaching.
6. Always use hazard flashers on the tractor when transporting unless prohibited by law.

When transporting the machine, review and follow these instructions:

1. Be sure all bystanders are clear of the machine.
2. Be sure that the machine is securely attached to the tractor and all retainer pins are installed.
3. Be sure you have installed extra weights on the front of the tractor if required.
4. Clean the SMV emblem, lights and reflectors and be sure they are working.
5. Be sure you are in compliance with all applicable lighting and marking regulations when transporting. Check with your local authorities.
6. Be sure your machine can clearly be seen by overtaking and oncoming traffic.
7. Keep to the right and yield the right-of-way to allow faster traffic to pass. Drive on the road shoulder if permitted by law.
8. Do not allow riders.
9. Always use hazard flashers on the tractor when transporting unless prohibited by law.

4.8 STORAGE



STORAGE SAFETY

1. Store the unit in an area away from human activity.
2. Do not permit children to play on or around the stored machine.
3. Store the unit in a dry, level area. Support the frame with planks if required.

After the season's use, the machine should be thoroughly inspected and prepared for storage. Repair or replace any worn or damaged components to prevent any unnecessary down time at the start of next season. To insure a long, trouble free life, this procedure should be followed when preparing the unit for storage:

1. Clear the area of bystanders, especially small children.
2. Thoroughly wash the machine using a pressure washer to remove all dirt, mud, debris and residue.
3. Inspect the wedge, strippers and wear plates for damage or entangled material. Repair or replace damaged parts. Remove all entangled material.
4. Touch up all paint nicks and scratches to prevent rusting.
5. Move to storage area.
6. Select an area that is dry, level and free of debris.
7. Fully retract the cylinder ram.
8. Unhook from tractor.
9. If the machine cannot be placed inside, cover with a waterproof tarpaulin and tie securely in place.
10. Store the machine in an area away from human activity.
11. Do not allow children to play on or around the stored machine.

5 SERVICE AND MAINTENANCE



MAINTENANCE SAFETY

1. Follow ALL the operating, maintenance and safety information in the manual.
2. Support the machine with blocks or safety stands when working beneath it.
3. Follow good shop practices.
 - Keep service area clean and dry.
 - Be sure electrical outlets and tools are properly grounded.
 - Use adequate light for the job at hand.
3. Make sure there is plenty of ventilation. Never operate the engine of the tractor in a closed building. The exhaust fumes may cause asphyxiation.
4. Use only tools, jacks and hoists of sufficient capacity for the job.
5. Make sure all guards are in place and properly secured when maintenance work is completed.
6. Keep hands, feet, hair and clothing away from moving or rotating parts.
7. Clear the area of bystanders, especially small children, when carrying out any maintenance and repairs or making any adjustments.

Good maintenance is your responsibility. Poor maintenance is an invitation to trouble.

DO NOT operate your Log Splitter in poor mechanical condition or when in need of repair.

As normal wear occurs, periodically adjust the bolts on the slide plate (beneath the splitting wedge) to eliminate excess space between the wedge plate and the beam. This assures long life to the cylinder and beam.

1. Loosen the 3 hex bolts on top of the slide plate.
2. Back the adjustment bolts on the side of the slide plate out slowly until the wedge assembly will slide on the beam. Tighten the lock nuts securely against the base of the slide plate to hold the bolts in this position.
3. Re-tighten the 3 hex bolts on top of the slide plate.

5.1 SERVICE

5.1.1 FLUIDS AND LUBRICANTS

1. **Grease:**
Use an SAE multi-purpose high temperature grease with extreme pressure (EP) performance. Also acceptable is an SAE multipurpose lithium base grease.
2. **Storing Lubricants:**
Your machine can operate at top efficiency only if clean lubricants are used. Use clean containers to handle all lubricants. Store them in an area protected from dust, moisture and other contaminants.

5.1.2 GREASING

Use a Maintenance Checklist to keep a record of all scheduled maintenance.

1. Use a hand-held grease gun for all greasing.
2. Wipe grease fitting with a clean cloth before greasing to avoid injecting dirt and grit.
3. Replace and repair broken fittings immediately.
4. If fittings will not take grease, remove and clean thoroughly. Also clean lubricant passage. Replace fitting if necessary.

5.1.3 SERVICING INTERVALS

The period recommended is based on normal operating conditions. Severe or unusual conditions may require more frequent servicing.

Daily or 10 Hours

1. Lubricate wedge frame wear plates.

Annually

1. Clean machine.

5.2 MAINTENANCE

By following a good maintenance program, your equipment will last for many years. With normal use the Log Splitter will not require any regular maintenance other than checking for loose bolts and the inspection of hoses and fittings.

If the wedge becomes dull or nicked, it can be removed and sharpened. Remove the 1/2" x 3" bolt that connects the wedge to the cylinder. The hose from the valve may need to be removed. Loosen the hose clamp and disconnect the hoses from the valve. While the log splitter is in the horizontal position, lift the cylinder to allow the wedge to slide forward. The wedge can now be lifted off and sharpened.

5.2.1 CHANGING SEALS IN VALVE

1. Clear the area of bystanders, especially small children before starting.
2. Turn tractor off and relieve pressure by operating the handle several times.
3. Be sure to wear a face shield to protect your eyes.
4. Order and obtain seal kit number A-7238.
 - a. 1 - 82527 O-ring (Item #16).
 - b. 1 - 82755 O-ring (Item #26).
 - c. 1 - 80311 O-ring (Item #14).
 - d. 1 - 82131 Back-up Washer (Item #12).
5. Remove control lever (Item #3); cotter pin (Item #20), pin (Item #19) and link (Item #27); allowing the handle to be removed from the end of the spool (Item #2).
6. Remove the handle bracket (Item #28) by removing the two screws (Item #13) with a screw driver.
7. Remove the two screws at the opposite end of the valve (Item #13) allowing removal of the spring cover (Item #19).
8. Carefully tap the spool towards the valve body from the handle (or yoked) end. A plastic or wooden screw driver handle is sufficient. Tap the spool back until you can pull the spool out of the valve body by hand.

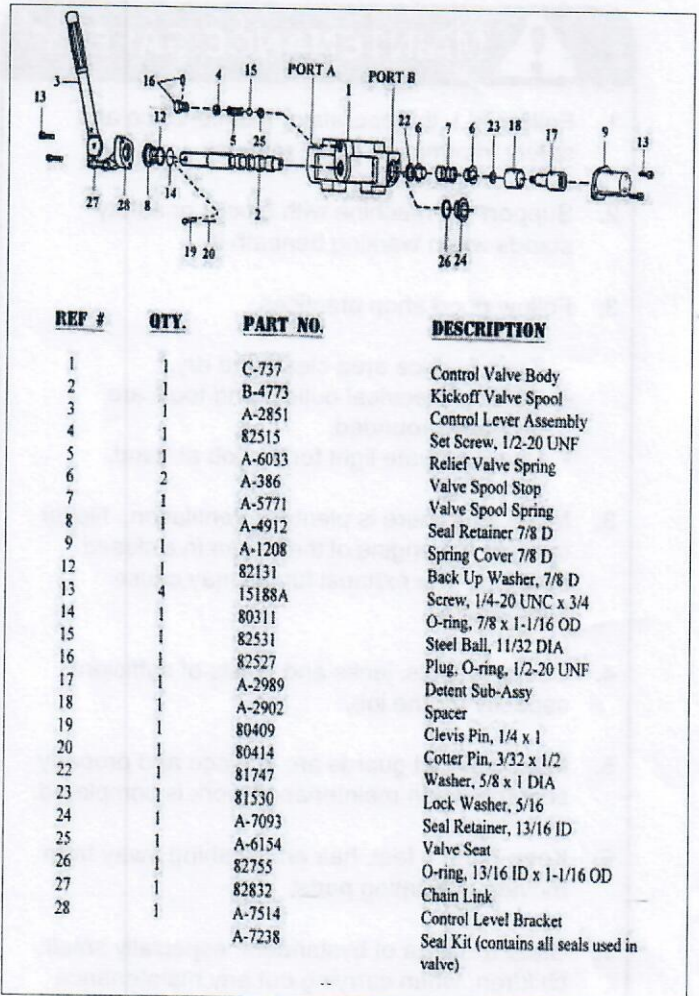

Fig. 17 VALVE EXPLODED VIEW

IMPORTANT

Do not force the spool, if you must exert more than 15 lbs. of pull on the detent sub-assembly something is jammed.

9. The o-ring (Item #26) closest to the detent sub-assembly (Item #17) will come out on the spool. Remove and replace with the new o-ring of like size. Remove the seal retainer (Item #8) from the handle end of the valve along with the o-ring (Item #14) and back-up washer (Item #12).
10. Install the valve spool in housing with the handle end entering the casting from the end marked "B". Turn the spool as you insert past the lands of the valve body (Item #1) and continue turning and pushing until the o-ring (Item #26) and seal retainer (Item #24) are into the valve body.

11. Place the o-ring (Item #14), back-up washer (Item #12), and seal retainer (Item #8) onto the handle end of the spool. Insert the o-ring and back-up into the seal groove on the control valve body (Item #1) with a blunt instrument.

IMPORTANT

If you cut the seal, oil will leak out of the end of the spool and may spray those standing near.

12. Slide the seal retainer into the control valve body (Item #1) and reverse Step #3.
13. Reverse Step #2 and assemble the control lever, pin, link and cotter pin.
14. Move the valve handle several times to insure the valve spool will freely move in the control valve housing. If it sticks, loosen the screws holding the handle bracket (Item #28) and spring cover (Item #9). Adjust the position of the handle bracket and spring cover until the spools slides freely. After freeing spool, retighten all four screws.

All replacement parts must meet manufacturer's specifications. The manufacturer will not be responsible for injuries or damages caused by use of unapproved parts and/or accessories.

5.3 PREMATURE KICK-OUT

Since the kick-out operates from hydraulic pressure (approx. 750 - 1250 PSI), you may experience the valve kicking out at start-up when the oil is cold. After the pump has run a few minutes, the system oil will warm and kick-out feature will operate correctly. This kick-out pressure is not adjustable. If it does not function properly, contact your dealer.

The kick-out operates by pilot pressure in the hydraulic system. If there is too much back pressure on the "out" port of the valve, such as the hose from the valve to reservoir being too small, the valve may kick-out prematurely. Also, if the cylinder or the Log Splitter ram "hangs up", the pressure may get too high. You need to have back pressure below 200 PSI to get the valve to operate properly.

6 TROUBLE SHOOTING

The 3 Point Hitch Mounted Log Splitter uses tractor hydraulic power to move wedge on the end of a cylinder to split wood or logs. It is a simple and reliable system that requires minimal maintenance.

In the following section, we have listed many of the problems, causes and solutions to the problems that you may encounter.

If you encounter a problem that is difficult to solve, even after having read through this trouble shooting section, please call your local dealer or distributor. Before you call, please have this Operator's Manual and the serial number from your Log Splitter ready.

PROBLEM	CAUSE	SOLUTION
Wedge doesn't move.	No power.	Place tractor circuit in detent to provide oil.
	Wood jammed around stripper.	Remove wood.
<hr/>		
Wedge jumps.	Wedge frame jamming.	Lubricate wedge frame wear plates.
		Turn wear plates over.
<hr/>		
Control lever does not stay in detent.	Cold oil.	Wait until oil warms.
		Run hydraulics over relief until oil warms.

7 SPECIFICATIONS

7.1 MECHANICAL

Tractor Categories:	I & II
Maximum Splitting Force	Depends on tractor*
Cycle Time:	Depends on tractor*
Maximum Log Length:	26"
Cylinder:	4" diameter x 24" stroke
Valve:	Auto-return
Beam Size:	6" x 6"
Wedge:	7" High with spreader wings
Hitch:	Tractor 3-point
Height:	42" Horizontal 72" Vertical
Width:	22"
Length:	72"
Shipping Weight:	365 lbs.

*Splitting force is determined by cylinder size and tractor PSI. Cycle time depends on cylinder size and GPM's that the tractor produces. Tractor should ideally produce 8-15 GPM at 1500 to 2500 PSI. Do not exceed 3200 PSI. See tables below for approximate splitting force and cycle time.

SPECIFICATIONS ARE SUBJECT TO CHANGE WITHOUT NOTICE

SPLITTING FORCE (TONS)

CYLINDER SIZE	1000 PSI	1500 PSI	2000 PSI	2500 PSI	3000 PSI	3500 PSI
3"	3.5	5.3	7.1	8.8	10.6	12.4
3 1/2"	4.8	7.2	9.6	12.0	14.4	16.8
4"	6.3	9.4	12.6	15.7	18.8	22.0
4 1/4"	7.1	10.6	14.2	17.7	21.3	24.8
4 1/2"	7.9	11.9	15.9	19.9	23.9	27.8
5"	9.8	14.7	19.6	24.5	29.5	34.3

CYCLE TIME (SECONDS)

CYLINDER SIZE	5 GPM	10 GPM	15 GPM	20 GPM	25 GPM
3" x 24"	15.4	7.7	5.1	3.9	3.1
3 1/2" x 24"	21.8	110.9	7.3	5.4	4.4
4" x 24"	28.3	14.2	9.4	7.1	5.7
4 1/4" x 24"	32.4	16.2	10.8	8.1	6.5
4 1/2" x 24"	36.6	18.3	12.2	9.2	7.3
5" x 24"	45.0	22.5	15.0	11.3	9.0



CAUTION: This Log Splitter is designed for tractors with pressure ratings under 3200 PSI. Warranty will be voided if used on tractors that exceed pressure settings of 3200 PSI. **DO NOT** exceed the pressure rating of the cylinder and valve manufacturers.

7.2 BOLT TORQUE

CHECKING BOLT TORQUE

The tables shown below give correct torque values for various bolts and capscrews. Tighten all bolts to the torques specified in chart unless otherwise noted. Check tightness of bolts periodically, using bolt torque chart as a guide. Replace hardware with the same strength bolt.

ENGLISH TORQUE SPECIFICATIONS

Bolt Diameter "A"	Bolt Torque *					
	SAE 2		SAE 5		SAE 8	
	N.m	(lb-ft)	N.m	(lb-ft)	N.m	(lb-ft)
1/4"	8	(6)	12	(9)	17	(12)
5/16"	13	(10)	25	(19)	36	(27)
3/8"	27	(20)	45	(33)	63	(45)
7/16"	41	(30)	72	(53)	100	(75)
1/2"	61	(45)	110	(80)	155	(115)
9/16"	95	(70)	155	(115)	220	(165)
5/8"	128	(95)	215	(160)	305	(220)
3/4"	225	(165)	390	(290)	540	(400)
7/8"	230	(170)	570	(420)	880	(650)
1"	345	(225)	850	(630)	1320	(970)

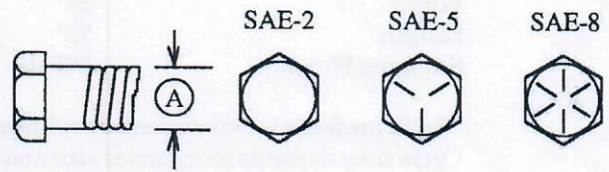

Torque figures indicated above are valid for non-greased or non-oiled threads and heads unless otherwise specified. Therefore, do not grease or oil bolts or capscrews unless otherwise specified in this manual. When using locking elements, increase torque values by 5%.

* Torque value for bolts and capscrews are identified by their head markings.

<u>REF #</u>	<u>QTY.</u>	<u>PART NO.</u>	<u>DESCRIPTION</u>
1	1	LS401182	Beam
2	1	LS401136	Wedge
3	1	O/L	Bolt 1/2" x 3"
4	1	O/L	Lock Washer, 1/2"
5	1	O/L	Nut, 1/2"
6	1	HC390118	Cylinder
7	1	P7910A	Hair Pin
8	1	P7712A	Pin
9	1	FW17316	Washer
10	2	HC390347	Fitting
11	1	HC390346	Tube
12	1	HC390343	Nipple 1/2" x 1/2"
13	2	HC390311	Reducer 3/4" - 1/2"
14	1	HC390406A	Valve, Auto-Return
15	1	HC390429A	Handle
16	1	P71022C	Pin
17	1	P7924	Hair Pin
18	1	LS400163	A-Frame
19	2	P728A	Lift Pin
20	3	O/L	Lock Washer, 7/8"
21	3	O/L	Nut, 7/8"
22	1	P794	Lynch Pin
23	1	P781A	Pin, Stub
24	8	O/L	Nut, 5/16"
25	8	O/L	Lock Washer, 5/16"
26	4	LS400164	Leg

Optional Closed Center Kit

1	HC390441E	Closed Spool Kit
---	-----------	------------------

O/L - Obtain Locally

8.2 HYDRAULIC VALVE ASSEMBLY

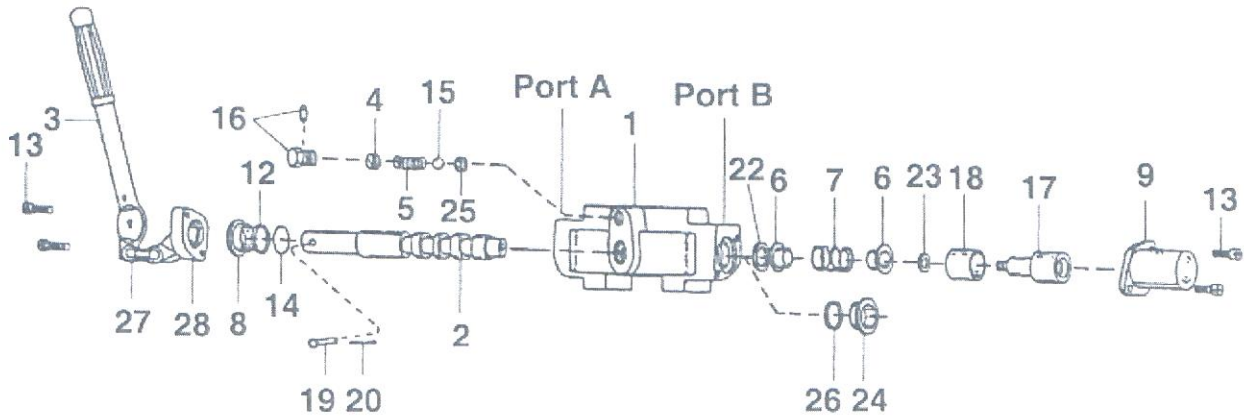

<u>REF #</u>	<u>QTY.</u>	<u>PART NO.</u>	<u>DESCRIPTION</u>
1	1	C-737	Control Valve Body
2	1	B-4773	Kickoff Valve Spool
3	1	A-2851	Control Lever Assembly
4	1	82515	Set Screw, 1/2 - 20 UNF
5	1	A-6033	Relief Valve Spring
6	2	A-386	Valve Spool Stop
7	1	A-5771	Valve Spool Spring
8	1	A-4912	Seal Retainer 7/8 D
9	1	A-1208	Spring Cover 7/8 D
12	1	82131	Back Up Washer, 7/8 D
13	4	15188A	Screw 1/4 - 20 UNC x 3/4
14	1	80311	O-Ring, 7/8 x 1 1/16 OD
15	1	82531	Steel Ball, 11/32 DIA
16	1	82527	Plug, O-Ring, 1/2 - 20 UNF
17	1	A-2989	Detent Sub-Assy
18	1	A-2902	Spacer
19	1	80409	Clevis Pin, 1/4 x 1
20	1	80414	Cotter Pin, 3/32 x 1/2
22	1	81747	Washer, 5/8 x 1 DIA
23	1	81530	Lock Washer, 5/16
24	1	A-7093	Seal Retainer, 13/16 ID
25	1	A-6154	Valve Seat
26	1	82755	O-Ring, 13/16 ID x 1 1/16 OD
27	1	82832	Chain Link
28	1	A-7514	Control Level Bracket
		A-7238	Seal Kit (contains all seals used in valve)

8.3 CONVERTING OPEN CENTER TO CLOSED CENTER VALVE

Instructions For Converting Open Center Log Splitter Valve To Closed Center Valve

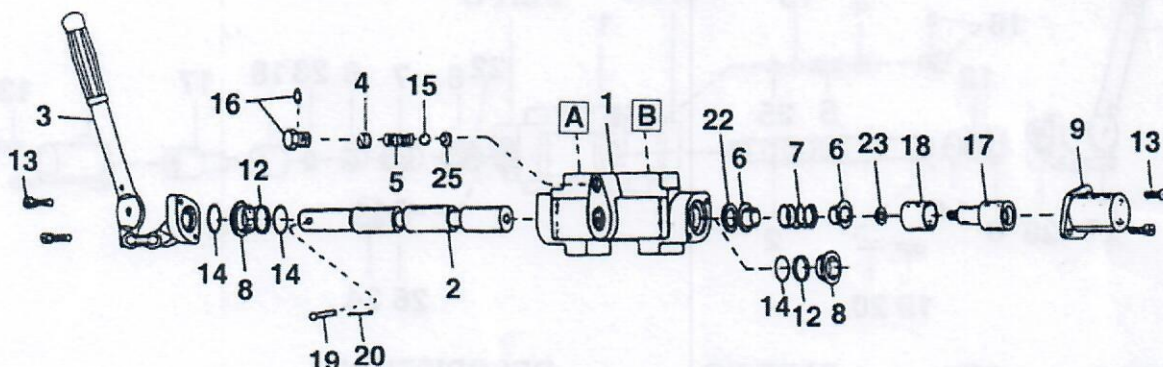

1. Place the valve with the handle end down in a vice.
2. Remove two $\frac{1}{4}$ - 20 UNC slotted screws (13), which hold the spring cover (9).
3. With a wide screwdriver or a $\frac{9}{16}$ " wide slotted socket adapter, remove the detent sub-assembly by unscrewing it from the spool. You may need to place a screwdriver or the handle in the opposite end to prevent the spool from turning. Remove the detent sub-assembly (17) and all parts including #22, machine bushing.
4. Turn the valve in the vice 90° and tap on the handle end of the spool lightly with a brass or rubber hammer or a piece of wood to push the spool (2), seal retainer (8), and o-ring (14) from the valve.
5. Pull and twist the spool (2) and remove carefully.
6. Take spool (2) from the kit and if the stud is not in the detent sub-assembly (17), but is still in the valve spool, remove the stud from the valve spool with an allen wrench and screw it into the new closed center spool (2).
7. Place the o-ring (14), back-up washer (12), and seal retainer (8) onto the spool. Place the spool in a vice vertically and clamp only on the flat milled handle end of the spool. Assemble the parts as shown on the diagram on the detent assembly (17) and screw detent assembly onto the new valve spool (2). Tighten the detent sub-assembly enough to flatten the lock washer (23).
8. Place the valve body vertically in the vice with the handle end down. Lubricate the valve spool with light oil or grease. Gently slide the valve spool into the valve body with the slotted end first. Tap the detent sub-assembly when resistance is met to push the spool through valve body. Install o-ring, back-up washer, and seal retainer over spool. Be certain the seal retainer is flush with the valve body.
9. Replace the valve spring cover and test the assembly by installing the handle and checking to be certain that the spring will return the valve to neutral when released. If not, loosen the spring cap to align and test the spring return several times before tightening. If it still will not return to neutral when released, lubricate. If it still will not return, check your assembly of the spring and parts (6), (7), and (18) spacer.
10. Remove the relief valve plug (16) and screw in the slotted screw until the spring bottoms. Replace decal with new one enclosed.
11. Your valve is now ready to be used on a "closed center" hydraulic system.



CAUTION: IF THE RELIEF VALVE IS NOT SCREWED SOLID, YOU COULD RUIN YOUR TRACTOR PUMP.